

Product Specification

Name: Low-voltage DMX controller with LCD display

Model: DMX301



I. Summarization

Low-voltage DMX controller with LCD display is a kind of controller with LCD digital display interface, used for control the RGB color change of 4 line 3 channels(common anode) LED lamps and brightness change of one channel, up to 34kinds of change programs to choose, at the same time can accept DMX-512 international standard digital control. Controller can be stand-alone operation, automatically online, accept standard DMX512 console control signal etc. method to work. According to the customer's actual demand, can achieve jumpy changing, gradual changing, stroboscopic such change effect.

II. Technical Parameters

- Working temperature: -20-60°C
- Power supply voltage: DC 12~24V
- Output voltage: DC 12~24V
- Output connect way: common anode 4 channels
- External dimension: L203XW134XH50 mm
- Packing size: L255XW155XH60 mm
- Net weight: 0.59kg
- Gross weight: 0.75kg
- Static power consumption: <3.96W
- Maximum output current: 8A/each channel
- Working frequency: 300Hz

III. External Dimension

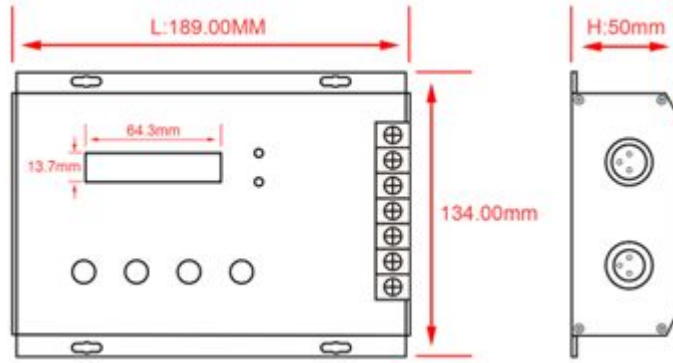

IV. Interface instruction:

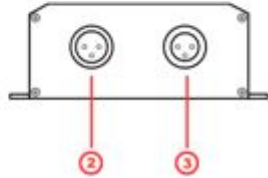
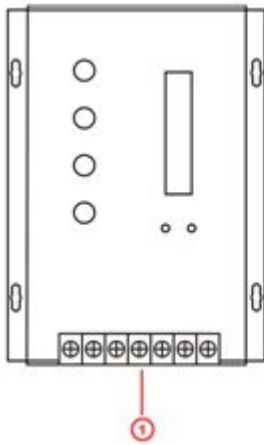

- ①fence type terminal ②XLR male port(input) ③XLR female port(input)

Fence type terminal with cover

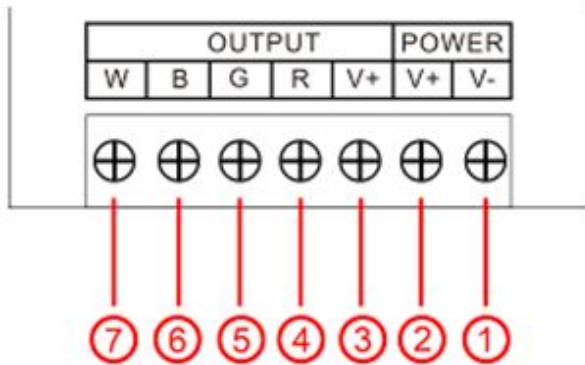

- ①.Power supply negative pole
 ②.Power supply positive pole
 ③.Load output common positive pole
 ④.Load red output pole
 ⑤.Load green output pole
 ⑥.Load blue output pole

DMX XLR interface

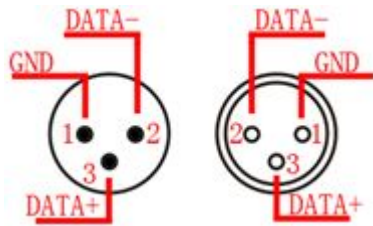

V. Product packing schematic diagram

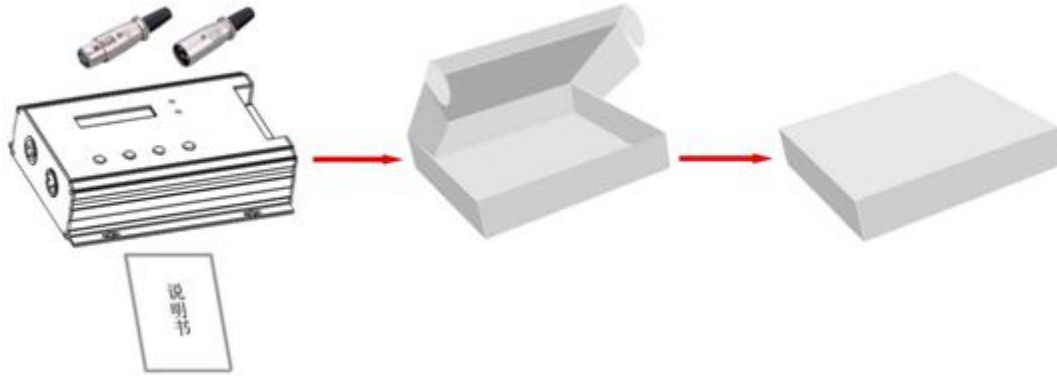

VI. Direction for use

1. Connect the load wire at first, following by the power wire; **Please ensure short circuit can not occur between connecting wire before you turn on the power.**

Controller have 4 function setting key: MODE, PARA, UP, DOWN.

2. MODE key choose in turn or press UP, DOWN key to choose:

No.	Display content	Instruction
0	BLACK	Static black
1	STATIC RED	Static red
2	STATIC GREEN	Static green
3	STATIC BLUE	Static blue
4	STATIC YELLOW	Static yellow
5	STATIC PURPLE	Static purple
6	STATIC CYAN	Static cyan
7	STATIC WHITE	Static white
8	COLOR CHANGE	Seven color jumpy changing
9	COLOR CHANGE2	Jumpy changing (flicker)
10	SIX COLOR CHANGE	Six color jumpy changing
11	SIX COLOR CHANGE2	Jumpy changing (flicker)
12	RGB CHANGE	Three color jumpy changing
13	RGB CHANGE2	Jumpy changing (flicker)
14	RG CHANGE	RG jumpy changing
15	RB CHANGE	RB jumpy changing
16	GB CHANGE	GB jumpy changing
17	WHITE CHANGE	White stroboflash
18	COLOR SMOOTH	Seven color gradual changing
19	4 COLOR SMOOTH	Four color gradual changing
20	RG SMOOTH	RG gradual changing

21	RB SMOOTH	RB gradual changing
22	GB SMOOTH	GB gradual changing
23	COLOR GRADUAL	Seven color fade in and out
24	RGB GRADUAL	Three color fade in and out
25	WHITE GRADUAL	White fade in and out
26	RG GRADUAL	RG fade in and out
27	RB GRADUAL	RB fade in and out
28	GB GRADUAL	GB fade in and out
29	R GRADUAL	R fade in and out
30	G GRADUAL	G fade in and out
31	B GRADUAL	B fade in and out
32	ADJUST MODE	Four channel, 0-255 level adjusted color
33	AUTO PROGRAM	Auto operation selecting result of changing
34	DMX512 MODE	DMX512 control order
35	DMX512 DECODER	DMX512 decoder

3. Press PARA to adjust in turn: (1—8 is static state, do not have adjust function)

No.	Parameters display	Instruction	
		Maximum	Minimum
1	RUN SPEED	100	0
2	RUN TIMES	100	0
3	LOAD DEFAULT	Restore the factory parameter	

4. UP: increase parameter key/preset parameter.

5. DOWN: decrease parameter/preset parameter.

6. AUTO PROGRAM mode is repeatedly cycle running part or all of 6-31 patterns run, you can set whether participating in repeated cycle of operation or not in RUN TIMES.

7. RUN TIMES: compiling the run times of the pattern under 33 AUTO PROGRAM, if the run times is 0, you can skip the pattern, that means not running the pattern.

8. Preset parameter: each form has independent factory preset parameter, which is kept in controller separate. LOAD DEFAULT can recover the factory parameter of the form. If under AUTO PROGRAM mode, using LOAD DEFAULT can unified recover the parameter of all forms to factory parameter.

9. 32 ADJUST MODE is manual dimming, it can adjust the brightness of RGB 0-256 level respectively.

10. 34 DMX512 MODE is controlling all patterns (the first address) and speed (the second address).

11. 35 DMX512 DECODER is DMX decoder, completely accepting outside DMX512 signal to work. Taking 4 addresses, R(the first address), G(the second address), B(the third address), reserved channel(the fourth channel), in need of setting address (by pressing PARA).

VII. Typical Applications

Typical application 1---do not have DMX function:

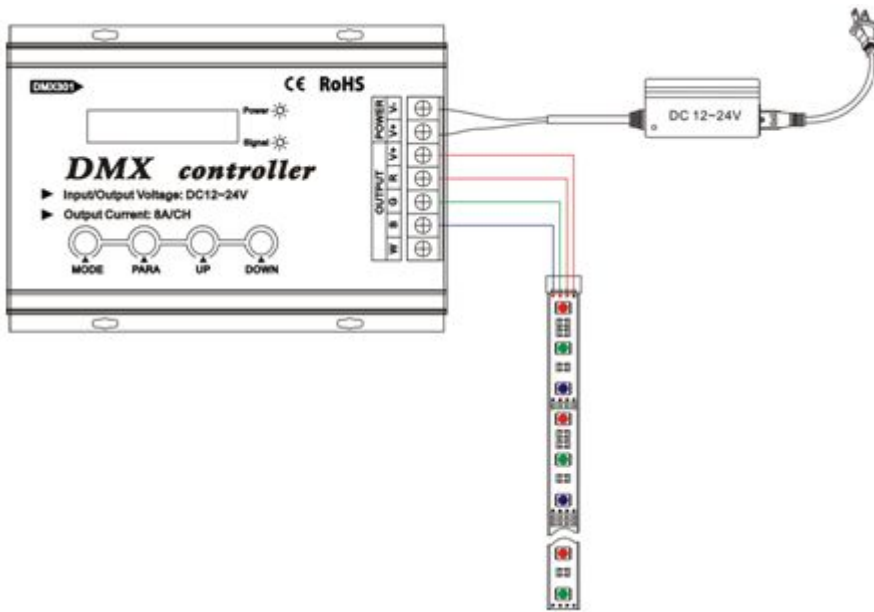

Typical application 2---with DMX function

