

4 Channel Constant Current DMX512 & RDM Decoder

Model No.: D4C(150-500mA) / D4C(350-1200mA)

Multiple current/RDM/Stand-alone function/Seven PWM frequency/Linear or logarithmic dimming/Numeric display/Din Rail

Features

- DC to DC constant current output, multiple output current settings.
- Comply with the DMX512 standard protocols.
- Digital numeric display, set DMX decode start address by buttons.
- RDM function can realize intercommunication between DMX master and decoder.
For example, DMX decoder address can be set by DMX master console.
- 1/2/4 DMX channel output selectable.
- 16bit (65536 levels) /8bit (256 levels) grey level selectable.
- PWM frequency 250/500/1000/2000/4000/8000/16000Hz selectable.
- Logarithmic or linear dimming curve selectable.
- Stand-alone RGB/RGBW mode and 4 channel dimmer mode selectable, which is controlled by buttons with built-in programs, instead of DMX signal.
- Available in white or black.

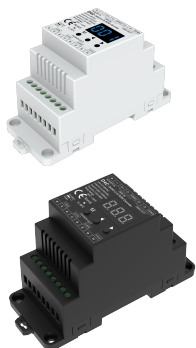

CE RoHS EMC LVD

Technical Parameters

Input and Output	
Input voltage	12-48VDC
Output voltage	4 x (3-4.5)VDC
Output current	4CH,150-500mA or 350-1200mA/CH
Output power	4 x (0.45-22.5)W (150-500mA) 4 x (1.05-54)W (350-1200mA)
Output type	Constant current
Warranty and Protection	
Warranty	5 years
Protection	Reverse Polarity Short circuit

Safety and EMC	
EMC standard [EMC]	ETSI EN 301 489-1 V2.2.3 ETSI EN 301 489-17 V3.2.4
Safety standard[LVD]	EN 62368-1:2020+A11:2020
Certification	CE,EMC,LVD
Environment	
Operation temperature	Ta: -30°C ~ +55°C
Case temperature [Max.]	Tc: +85°C
IP rating	IP20

LED Current Selection

D4C (150-500mA)	Output Current	150mA	200mA	250mA	300mA	350mA	400mA	450mA	500mA	
	Output Voltage	3-4.5V	3-4.5V	3-4.5V	3-4.5V	3-4.5V	3-4.5V	3-4.5V	3-4.5V	3-4.5V
	Output Power/CH	0.45-6.75W	0.6-9W	0.75-11.25W	0.9-13.5W	1.05-15.75W	1.2-18W	1.35-20.25W	1.5-22.5W	
D4C (350-1200mA)	Output Current	350mA	500mA	600mA	700mA	800mA	900mA	1050mA	1200mA	
	Output Voltage	3-4.5V	3-4.5V	3-4.5V	3-4.5V	3-4.5V	3-4.5V	3-4.5V	3-4.5V	
	Output Power/CH	1.05-15.75W	1.5-22.5W	1.8-27W	2.1-31.5W	2.4-36W	2.7-40.5W	3.15-47.25W	3.6-54W	

Mechanical Structures and Installations

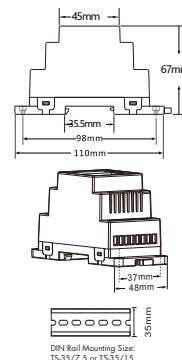
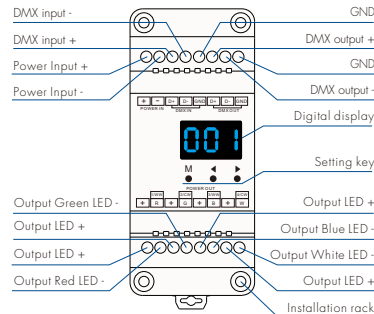

Wiring Diagram

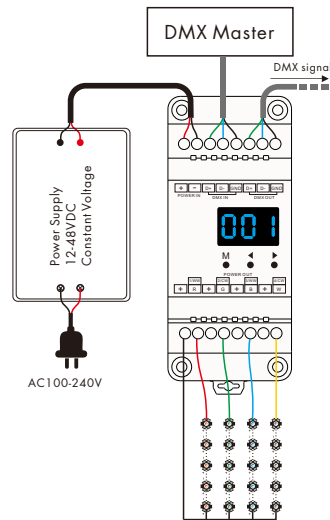

Note:

1. The LED quantity at each channel can be different, the decoder could auto check and output a proper voltage to each channel according to its LED quantities.
2. The decoder works on buck mode, the voltage of power supply should be greater than the total voltage of the series LEDs.
3. An DMX signal amplifier is needed if more than 32 decoders are connected, or use overlong signal line, signal amplification should not be more than 5 times continuously.
4. If the recoil effect occurs because of longer signal line or bad line quality, please try to connect 0.25W 90-120Ω terminal resistor at the end of each line.

Drives 1-13pcs LED per channel x 4CH

Operation

System parameter setting

- Long press M and ◀ key in the same time for 2s, prepare for setup system parameter: short decode mode, grey level, output PWM frequency, output brightness curve, default output level, automatic blank screen. short press M key to switch six item.
- Decode mode: short press ◀ or ▶ key to switch 1/2/4 channel decode mode("d1", "d2" or "d4"). When set as 1 channel decode, the decoder occupy only 1 DMX address, and four channel output the same brightness of this DMX address.
- Grey level: short press ◀ or ▶ key to switch 8bit("b08") or 16 bit("b16"). choose 16 bit if the DMX master support 16 bit.
- Output PWM frequency: short press ◀ or ▶ key to switch 250Hz("F02"), 500Hz("F05"), 1000Hz("F10"), 2000Hz("F20"), 4000Hz("F40"), 8000Hz("F80") or 16000Hz("F16").
- Output brightness curve: short press ◀ or ▶ key to switch linear curve("C1") or logarithmic curve("CE").
- Default output level: press ◀ or ▶ key to change default 0-100% level ("d00" to "dFF") when no DMX input signal.
- Automatic blank screen: short press ◀ or ▶ key to switch enable ("bon") or disable("bof") automatic blank screen.
- Long press M key for 2s or timeout 10s, quit system parameter setting.

Output current setting

- Please select the correct current firstly when the LED load is disconnected.
- Long press M and ▶ key in the same time for 2s, prepare for setup output current.
- For D4C(150-500mA): short press ◀ or ▶ key to switch 150mA("C15"), 200mA("C20"), 250mA("C25"), 300mA("C30"), 350mA("C35"), 400mA("C40"), 450mA("C45") or 500mA("C50").
- For D4C(350-1200mA): short press ◀ or ▶ key to switch 350mA("C35"), 500mA("C50"), 600mA("C60"), 700mA("C70"), 800mA("C80"), 900mA("C90"), 1050mA("CA5") or 1200mA("CC0").
- Press M key or timeout 10s, quit output current setting.

DMX mode

- Short press M key, when display 001~512, enter DMX mode.
- Press ◀ or ▶ key to change DMX decode start address(001~512), long press for fast adjustment.
- If there is a DMX signal input, will enter DMX mode automatically.
- DMX Dimming: Each D4C DMX decoder occupy 4 DMX address when connecting the DMX console.
For example, the defaulted start address is 1, their corresponding relationship in the form:



DMX mode
(001~512)

DMX Console	DMX Decoder Output
CH1 0-255	CH1 PWM 0-100% (LED R)
CH2 0-255	CH2 PWM 0-100% (LED G)
CH3 0-255	CH3 PWM 0-100% (LED B)
CH4 0-255	CH4 PWM 0-100% (LED W)

Stand-alone RGB/RGBW mode

- Enter stand-alone RGB/RGBW mode only when DMX signal is disconnected or lost.
- Short press M key, when display P01~P30, enter stand-alone RGB/RGBW mode.
- Press ◀ or ▶ key to change dynamic mode number(P01~P30).
- Each mode can adjust speed and brightness.
Long press M key for 2s, prepare for setup mode speed, brightness, W channel brightness.
Short press M key to switch three item.
Press ◀ or ▶ key to setup value of each item.
Mode speed: 1-10 level speed(S-1, S-9, S-F).
Mode brightness: 1-10 level brightness(b-1, b-9, b-F).
W channel brightness: 0-255 level brightness(400-4FF).
Long press M key for 2s, or timeout 10s, quit setting.



Stand-alone RGB/RGBW mode
(P01~P30)



Speed
(8 level)



Brightness
(10 level, 100%)

Stand-alone dimmer mode

- Enter stand-alone dimmer mode only when DMX signal is disconnected or lost.
- Short press M key, when display L-1~L-8, enter stand-alone dimmer mode.
- Press ◀ or ▶ key to change dimmer mode number(L-1~L-8).
- Each dimmer mode can adjust each channel brightness independently.
Long press M key for 2s, prepare for setup four channel brightness.
Short press M key to switch four channel(100~1FF, 200~2FF, 300~3FF, 400~4FF).
Press ◀ or ▶ key to setup brightness value of each channel.
Long press M key for 2s, or timeout 10s, quit setting.



Stand-alone dimmer mode
(L-1~L-8)

Restore factory default parameter

- Long press ◀ and ▶ key for 2s, restore factory default parameter, display "RES".
- Factory default parameter: DMX decode mode, DMX decode start address is 1, four channel decode, 8 bit grey level, 4000Hz PWM frequency output, 350mA or 700mA output current, logarithmic brightness curve, output 100% level when no DMX input, RGB mode number is 1, dimmer mode number is 1, disable automatic blank screen.

RGB mode list

No.	Name	No.	Name	No.	Name
P01	Static red	P11	Green strobe	P21	Red yellow smooth
P02	Static green	P12	Blue strobe	P22	Green cyan smooth
P03	Static blue	P13	White strobe	P23	Blue purple smooth
P04	Static yellow	P14	RGB strobe	P24	Blue white smooth
P05	Static cyan	P15	7 color strobe	P25	RGB+W smooth
P06	Static purple	P16	Red fade in and out	P26	RGBW smooth
P07	Static white	P17	Green fade in and out	P27	RGBY smooth
P08	RGB jump	P18	Blue fade in and out	P28	Yellow cyan purple smooth
P09	7 color jump	P19	White fade in and out	P29	RGB smooth
P10	Red strobe	P20	RGBW fade in and out	P30	6 color smooth

Dimming curve setting

Linear dimming curve

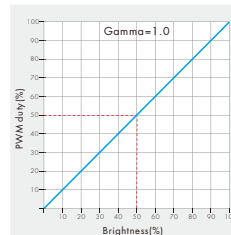

Logarithmic dimming curve

