

# 5 Channel Constant Voltage DMX512 & RDM Decoder / Master



Model No.: D5

RDM/Stand-alone function/8 bit or 16bit decode/Four PWM frequency/Multiple dimming curve/OLED display

## Features

- 5 channels constant voltage output, Max. 6A current per channel, up to 720W output power.
- Master & decoder mode, RDM function.
- Easy operation with OLED display and 3 buttons.
- 1/2/3/4/5 channel decoding mode selectable.
- PWM frequency 250/500/2000/8000Hz selectable.
- 16bit (65536 levels) /8bit (256 levels) grey level selectable.
- Output dimming curve gamma value 0.1-9.9 selectable.
- Stand-alone RGB mode and 5 channel dimmer mode selectable, work as DMX master(8 bit) to control other decoders.
- Built-in 25 RGB programs, speed and brightness adjustable.
- Support 3 kinds of DMX ports: Green terminal(amplify output), XLR3 and RJ45 port.
- Comply with the DMX512 standard protocols.
- Over-heat / Over-load / Short circuit protection, recover automatically.
- With fast self-testing function.



## Technical Parameters

Input and Output	
Input voltage	12-24VDC
Input current	30.5A
Output voltage	5 x (12-24)VDC
Output current	5CH,6A/CH
Output power	5 x (72-144)W
Output type	Constant voltage

Environment	
Operation temperature	Ta: -30°C ~ +55°C
Case temperature (Max.)	Tc: +85°C
IP rating	IP20

Safety and EMC	
EMC standard (EMC)	EN55032:2015, EN61000-3-2:2014, EN61000-3-2:2013, EN55024 :2010/A1:2015
Safety standard(LVD)	EN 61347-1:2015 EN 61347-2-11:2015
Certification	CE,EMC,LVD

Warranty and Protection	
Warranty	5 years
Protection	Reverse Polarity Over-heat Over-load Short circuit

## Mechanical Structures and Installations

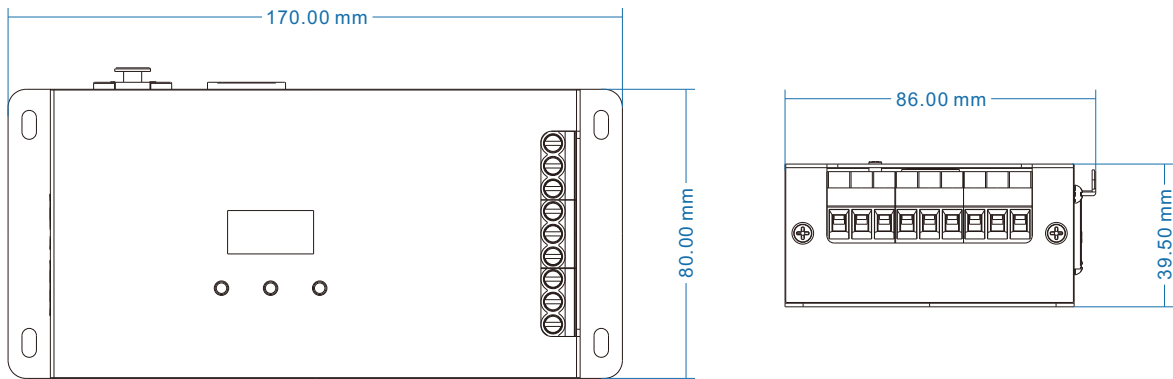
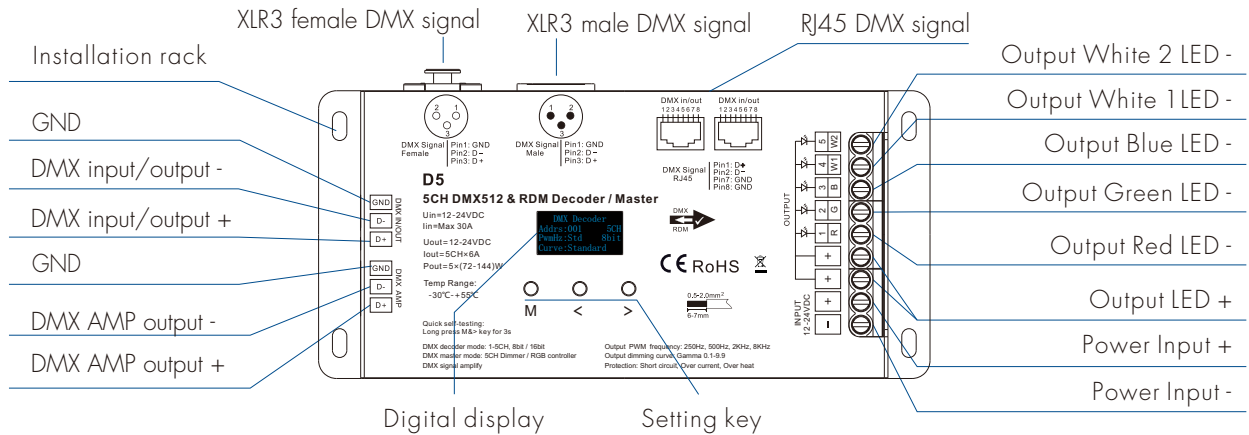

## Wiring Diagram

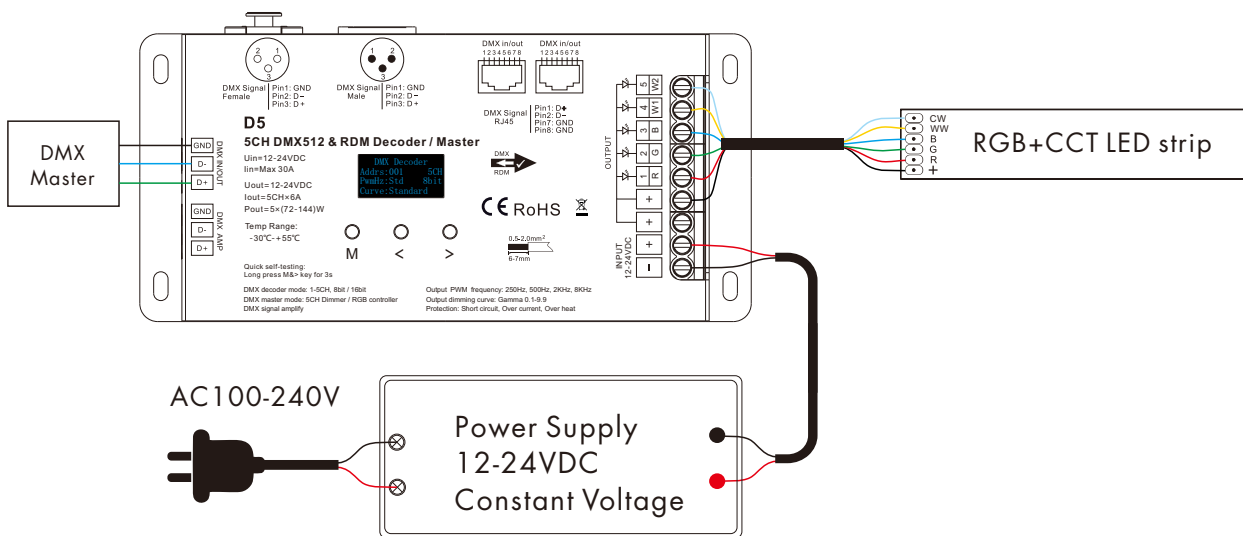

Note:

1. Connecting with green terminal (DMX AMP) or an extra amplifier will be needed when more than 32 decoders are connected, or use overlong signal line, signal amplification should not be more than 5 times continuously.
2. If the recoil effect occurs because of longer signal line or bad line quality, please try to connect 0.25W 90-120Ω terminal resistor at the end of each DMX signal line.

## OLED screen interface

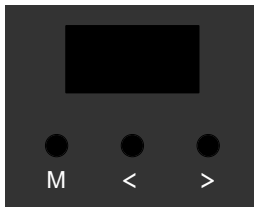

Short press M key, switch between DMX decoder mode, Dimmer mode and RGB controller mode.  
 Long press M key or short press < or > key, enter parameter setting state.  
 When in parameter setting state, short press M key to switch between multiple parameter item,  
 press < or > key for parameter adjustment.  
 long press M key or wait 30 seconds to quit parameter setting state.  
 Long press M & > key for 3s, enter fast self-testing.  
 Long press < & > key for 3s, restore factory default parameter.

### DMX decoder mode

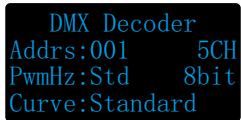

DMX decode start address:  
 Range: 001~999

DMX decode mode:  
 1CH (DIM) 2CH (CCT) 3CH (RGB) 4CH (RGBW) 5CH (RGB+CCT)

Output PWM frequency:

- Std (2KHz)
- High (8KHz) Higher PWM frequency, will cause lower output current,
- Mid (500Hz) higher power noise, but more suitable for camera(No flickers for video).
- Low (250Hz)

Grey level:

- 8bit
- 16bit (choose it if the DMX master support 16 bit)

Output dimming curve:

- Standard (Gamma 1.6)
- Linear
- Gamma0.1-9.9

It is recommended to use standard,  
 0.1-9.9 is for special requirements.

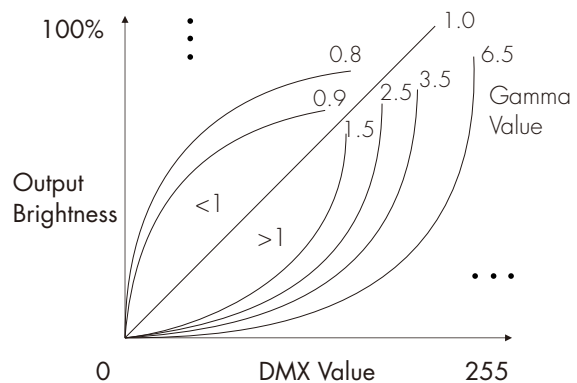

### DMX master mode as 5 channel dimmer

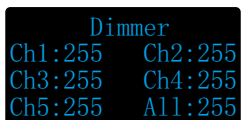

Each or all channel brightness setting:  
 Range: 0-255

### DMX master mode as RGB controller



Dynamic RGB mode list:

No.	Name	No.	Name	No.	Name
01	Static Red+strobe	09	R/G/B gradual	17	Green/White gradual
02	Static Green+strobe	10	Color gradual	18	Blue/White gradual
03	Static Blue+strobe	11	R/G/B fade	19	Red/Yellow gradual
04	Static White+strobe	12	Red fade	20	Red/Purple gradual
05	R/G/B jump	13	Green fade	21	Green/Yellow gradual
06	7 Color jump	14	Blue fade	22	Green/Cyan gradual
07	R/G/B strobe	15	White fade	23	Blue/Purple gradual
08	7 Color strobe	16	Red/White gradual	24	Blue/Cyan gradual
				25	All loop play

Dynamic RGB mode:

25 kinds

Mode speed:

Range: 1-10 level

Mode brightness:

Range: 10%-100%

Ch4 brightness:

Range: 0-255

Ch5 brightness:

Range: 0-255

## Address setting table

8bit:

Decode Mode		1CH DIM	2CH CCT	3CH RGB	4CH RGBW	5CH RGB+CCT
Address Quantity		1	2	3	4	5
Channel	1	001	001	001	001	001
	2	001	002	002	002	002
	3	001	001	003	003	003
	4	001	002	003	004	004
	5	001	002	003	004	005

16bit:

Decode Mode		1CH DIM	2CH CCT	3CH RGB	4CH RGBW	5CH RGB+CCT
Address Quantity		2	4	6	8	10
Channel	1	001 002	001 002	001 002	001 002	001 002
	2	001 002	003 004	003 004	003 004	003 004
	3	001 002	001 002	005 006	005 006	005 006
	4	001 002	003 004	005 006	007 008	007 008
	5	001 002	003 004	005 006	007 008	009 010

Note: even channel for micro dimming.

## Malfunctions analysis & troubleshooting

Malfunctions	Causes	Troubleshooting
No light	<ol style="list-style-type: none"> <li>No power.</li> <li>Wrong connection or insecure.</li> </ol>	<ol style="list-style-type: none"> <li>Check the power.</li> <li>Check the connection.</li> </ol>
Wrong color	<ol style="list-style-type: none"> <li>Wrong connection of R/G/B/W wires.</li> <li>DMX decode address error.</li> </ol>	<ol style="list-style-type: none"> <li>Reconnect R/G/B/W wires.</li> <li>Set correct decode address.</li> </ol>
Uneven intensity between front and rear, with voltage drop	<ol style="list-style-type: none"> <li>Output cable is too long.</li> <li>Wire diameter is too small.</li> <li>Overload beyond power supply capability.</li> <li>Overload beyond controller capability.</li> </ol>	<ol style="list-style-type: none"> <li>Reduce cable or loop supply.</li> <li>Change wider wire.</li> <li>Replace higher power supply.</li> <li>Add power repeater.</li> </ol>