

User Guide

AC Triac RF + Push Dimmer

The S1-B is an innovative AC phase-cut dimmer with both RF control and push dim function. The AC dimmer is designed with 100-240VAC wide input and output, 1 channel output, both triac dimmable and mosfet dimmable. The RF triac dimmer can be compatible with a variety of single color RF series remote controls. While working with a WiFi-Relay controller, the dimmer can be WiFi controlled via APP installed on IOS or Android system. Push dim function is available while the dimmer is connected with a push switch.

Feature

- AC phase-cut RF dimmer with push-dim function, 1 channel output.
- To dim and switch single color dimmable LED lamps or drivers, traditional incandescent and halogen lights.
- Suitable to insert standard panel bottom box.
- Smooth dimming and switch without any flickering.
- Adopt 2.4GHz wireless technology, remote distance up to 30m.
- Leading edge dimming or trailing edge dimming set by dip switch.
- Great compatibility with a variety of dimming RF remote.
- Work with WiFi-relay controller after install APP on IOS and Android system.

Technical parameter

Model	Input voltage	Output voltage	Output current	Output power
S1-B	100-240VAC	100-240VAC	1.0A	100-240W

Note: When calculating the maximum number of load lamps or drivers, the input power or input current parameters of a single lamp or driver must be used, the output power parameters can not be used, otherwise, the product will be overloaded and damaged.

Dimension

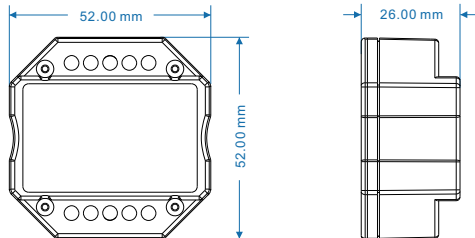

Interface specification

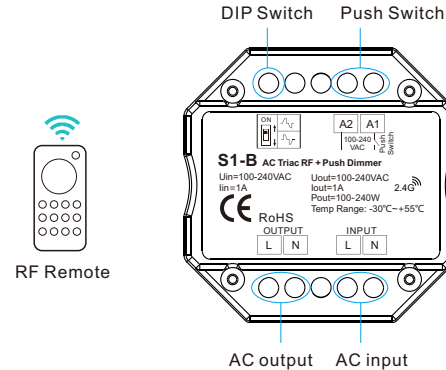

Select leading edge (forward-phase) dimmer or trailing edge (reverse-phase) dimmer according to dimmable LED light or driver.

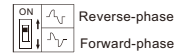

Forward-phase control dimmer (TRIAC)

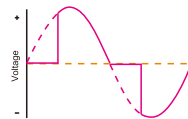

Reverse-phase control dimmer



Caution: before power on, you must confirm the selection of dip switch.

Match guide

Use power-up to match the AC triac dimmer with the RF remote.

1. Match: Switch off the power, then switch on power again, short press on/off key or zone key 3 times on the remote quickly within 5s after power on, the link is done once the light blinks 3 times.
2. Delete: Switch off the power, then switch on power again, short press on/off key or zone key 5 times on the remote quickly within 5s after power on, the unlink is done once the light blinks 5 times.
3. Multiple zone remote only use zone key to match each zone receiver.

Wiring diagram

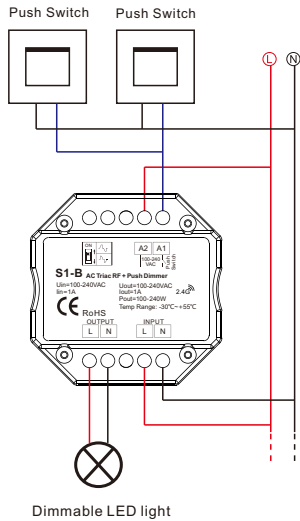

S1-B connect with dimmable LED light

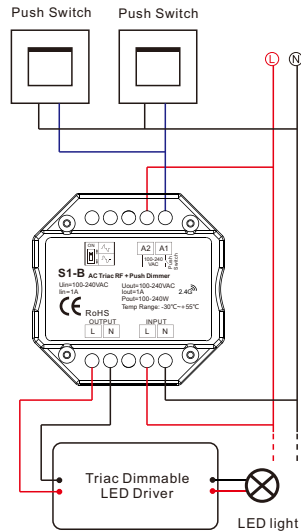

S1-B connect with dimmable LED driver

Push switch function (optional)

1. Short press: Turn on/off light.
2. Long press(1-5s): When light is on, increase or decrease brightness continuously.
3. Long press(10s): When multiple dimmers share a push switch, achieve simultaneous adjustment.

Malfunctions analysis & troubleshooting

Malfunctions	Causes	Troubleshooting
No light	<ol style="list-style-type: none"> 1. No power. 2. Wrong connection or insecure. 	<ol style="list-style-type: none"> 1. Check the power. 2. Check the connection.
No response from the remote	<ol style="list-style-type: none"> 1. The battery has no power. 2. Beyond controllable distance. 3. The controller did not match the remote. 	<ol style="list-style-type: none"> 1. Replace battery. 2. Reduce remote distance. 3. Re-match the remote.

Safety information

1. The product shall be installed and serviced by a qualified person.
2. This product is non-waterproof. Please avoid the sun and rain.
3. Good heat dissipation will prolong the working life of the controller, please ensure good ventilation.
4. Please check if the output voltage of any power supplies used comply with the working voltage of the product.
5. Ensure all wire connections and polarities are correct and secure before applying power to avoid any damages to the LED lights.
6. If a fault occurs please return the product to your supplier. Do not attempt to fix this product by yourself.