

WiFi & RF 3-Button LED Dimmer

Model No.: VD1(WT)

Tuya APP cloud control / Voice control / 3-button / Wireless remote control / Step-less dimming

Features

- WiFi & RF 1 channel constant voltage single color LED dimmer.
- 5A output, connect with 5 meters single color LED strip.
- Tuya APP cloud control, support on/off, brightness adjust, delay turn on/off light, timer run, scene edit function.
- Voice control, support for Amazon Alexa, Google Assistant, Tmall Genie and Xiaodu smart speakers.
- 3 button operation with on/off and dimming.
- Match with 2.4G single zone or multiple zone single color remote control optional.
- 4096 levels 0-100% dimming smoothly without any flash.



CE RoHS RED

Technical Parameters

Input and Output		Dimming data		Safety and EMC	
Input voltage	5-24VDC	Input signal	Tuya APP + RF 2.4GHz + 3 button	EMC standard (EMC)	ETSI EN 301 489-1 V2.2.3 ETSI EN 301 489-17 V3.2.4
Output voltage	5-24VDC	Control distance	30m(Barrier-free space)	Safety standard	EN 62368-1:2020+A11:2020
Output current	Max. 5A	Dimming level	4096 (2 ¹²) levels	Radio Equipment(RED)	ETSI EN 300 328 V2.2.2
Output power	25W@5V 60W@12V 120W@24V	Dimming range	0-100%	Certification	CE,EMC,RED
Environment		Dimming curve	Logarithmic	Package	
Operation temperature	Ta: -30°C ~ +50°C	PWM Frequency	2KHz (default)	Size	W120 x L43 x H27mm
Case temperature (Max.)	Tc: +85°C	Warranty	5 years	Gross weight	0.013kg
		Protection	Over-heat, Short circuit		

Dimension

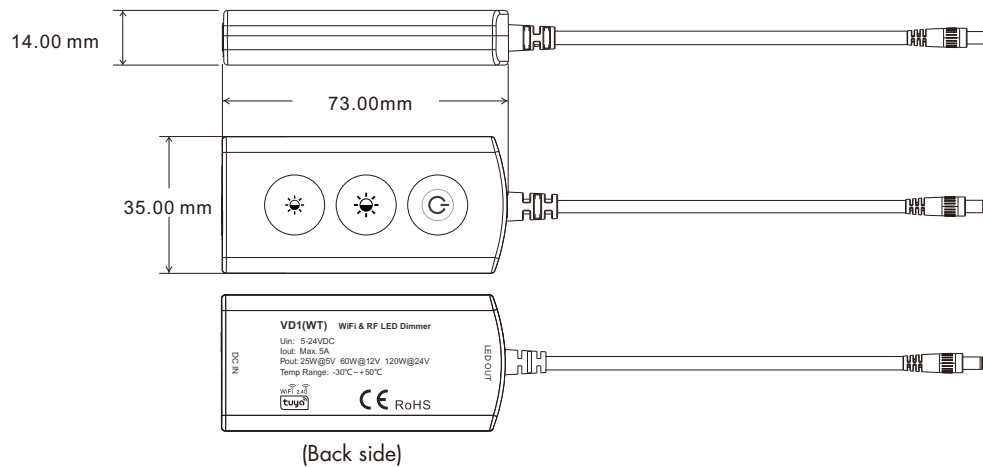

Wiring Diagram

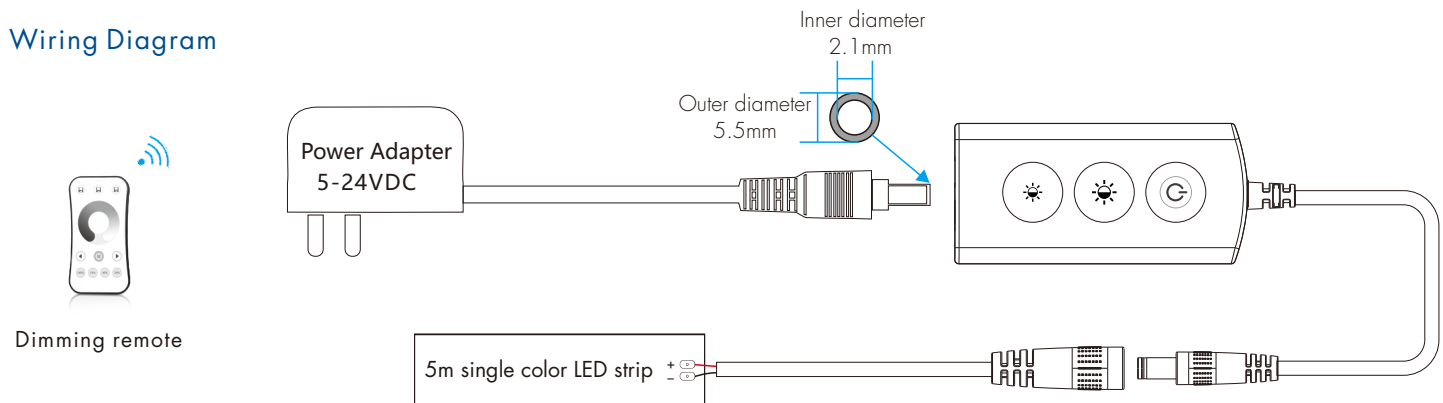

Note: Press and hold the and (Brightness-) button for 2s, output LED flashes 3 times, the light on/off fade time will change between 3s and 0.5s.

System Wiring

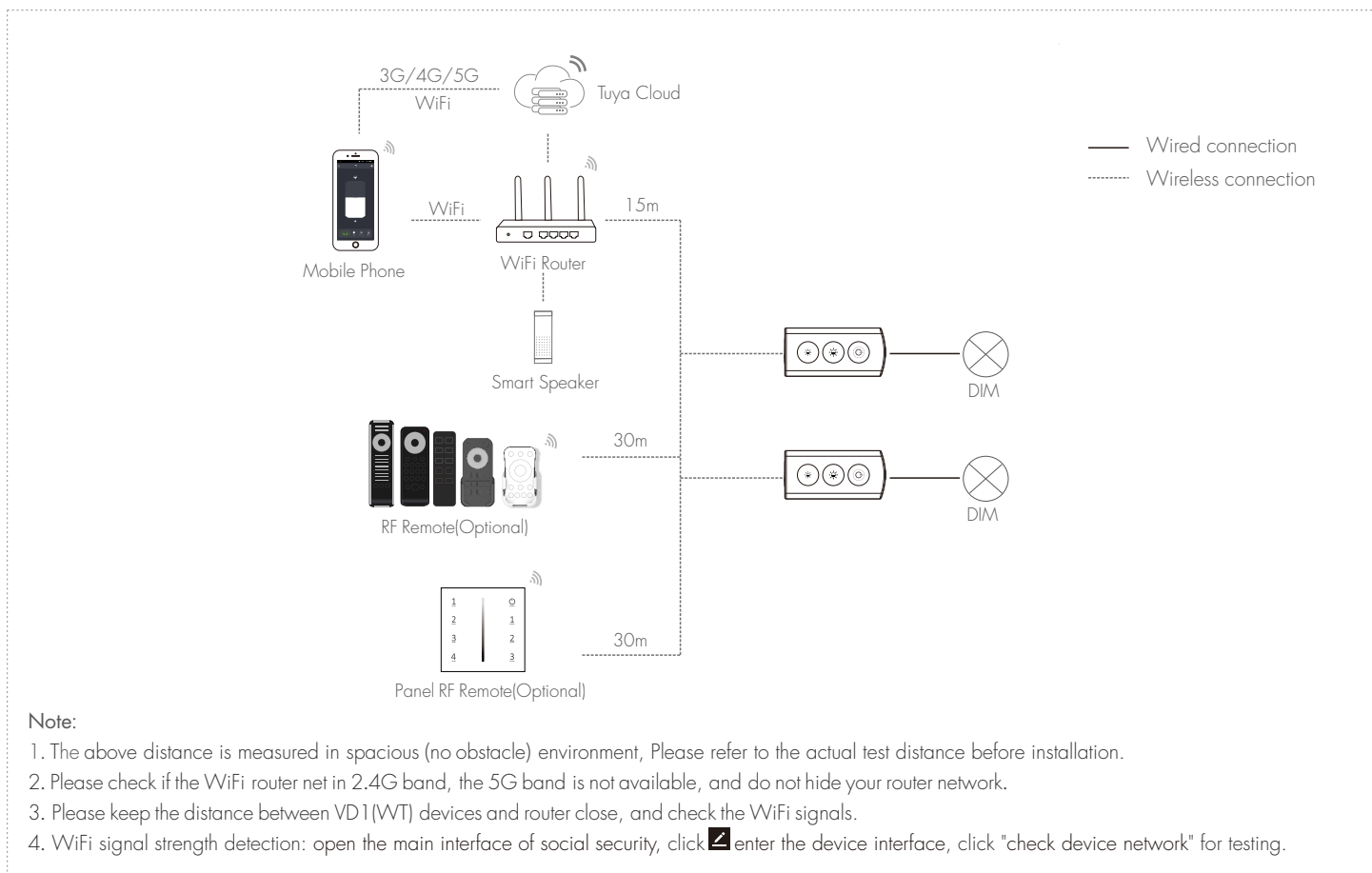

Button function



: Turn on or off light.



: Brightness +, short press 10 levels, long press 1-6s for continuous 256 levels adjustment.



: Brightness -, short press 10 levels, long press 1-6s for continuous 256 levels adjustment.

Tuya APP network connection

Please download the corresponding tuya/smart life app according to your region.

Press and hold and (Brightness+) button for 2s:
clear previous network connection, enter Smart config mode, the output LED will flash 10 times.

Press and hold and (Brightness+) button for 5s:
Clear previous network connection, enter AP config mode, the output LED will flash 5 times.
If smart config failed, please try AP config.

Repeat power on and off for 5 consecutive times, also clear previous network connection,
enter Smart config mode, the output LED will flash 10 times.

If Tuya APP network connection succeed, the output LED will stop flash,
and in Tuya APP, you can find DIMc device .



Smart life APP



Tuya APP

Tuya APP interface



White interface
Touch brightness slide to adjust brightness.

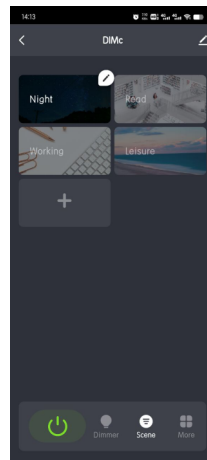

Scene interface
The 1-4 scene is static color.
the inner color of these scene can be editable.

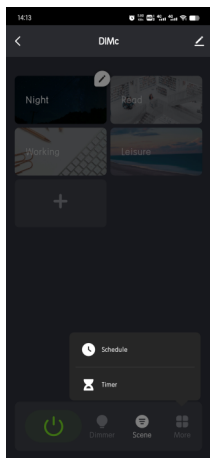

Timer, Schedule
The Schedule key can add multiple timers to turn on or turn off light according to different time periods.
The Timer key can turn on or turn off light in the next 24 hours.

Match Remote Control (optional)

End user can choose the suitable match/delete ways. Two options are offered for selection:

Use and button

Match:
Long press and button 2s, immediately press on/off key (single zone remote) or zone key (multiple zone remote) of the remote.

Delete:
Press and hold and button for 5s to delete all match,
The output LED blinks 5 times means all matched remotes were deleted.

Use Power Restart

Match:
Switch off the power, then switch on power again, immediately short press on/off key (single zone remote) or zone key (multiple zone remote) 3 times on the remote.
The output LED blinks 3 times means match is successful.

Delete:
Switch off the power, then switch on power again, immediately short press on/off key (single zone remote) or zone key (multiple zone remote) 5 times on the remote.
The output LED blinks 5 times means all matched remotes were deleted.

Dimming Curve

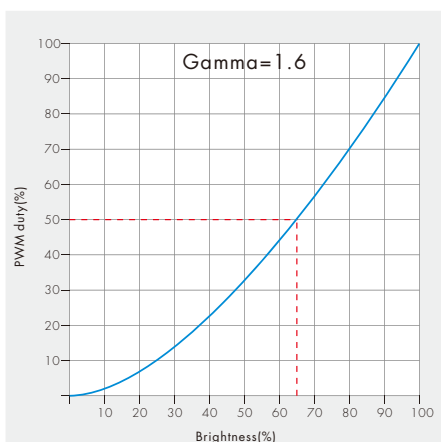

Packing list



LED Dimmer
1 pcs



User Manual
1 pcs



DC Extension Cable
(12cm)
1 pcs