

LED Intelligent Driver (CV)

- Dimming range: 0~100%, LED start at 0.1% possible.
- 0-100% flicker-free, High frequency exemption level.
- Dimming interfaces: DALI-2, Push DIM, 0-10V, 1-10V, 10V PWM, RESISTANCE DIM
- High Efficient driver: PF>0.96, THD<10%
- Over load / Over temp. / Short circuit / Over voltage protection, recover automatically.
- Suitable for internal lights application for I / II / III.
- Up to 50000-hour life time.

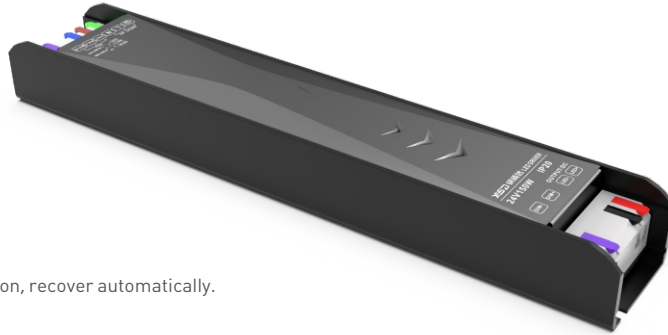

0-10V
 1-10V
 10V PWM
 Resistance DIM
 DALI-2
 PUSH DIM

PF>0.96

THD<10%

Flicker-free
 IEEE 1789
 High frequency exemption level



SELV IP20



Specification

Model	YSD-150WUDL-12D	YSD-150WUDL-24D	YSD-150WUDL-36D	YSD-150WUDL-48D	
OUTPUT	Output voltage	12VDC	24VDC	36VDC	48VDC
	Output voltage range	12VDC±0.3VDC	24VDC±0.6VDC	36VDC±0.6VDC	48VDC±0.6VDC
	Output current	Max 12.5A	Max 6.25A	Max 4.17A	Max 3.13A
	Output power	Max 150W			
	Output power range	0~150W			
	With or without strobe	No strobe			
	Dimming range	0~100%, dimming depth: Max. 0.1%			
	Ripple & Noise	≤150mV	≤240mV	≤360mV	≤480mV
PWM frequency	4-16Khz				
INPUT	Dimming interface	DALI-2 / PUSH DIM / 0-10V / 1-10V / 10V PWM / RESISTANCE DIM (0-100K)			
	Input voltage	100-264Vac			
	Frequency	50/60Hz			
	Input current	1.8~0.6A			
	Power factor	PF>0.96/230Vac, at full load			
	THD	≤10% at 230Vac, at full load			
	Efficiency (typ.)	92%	93%	93%	93%
	Inrush current (typ.)	Cold start 50A at 230Vac			
	Control surge capability	L-N:1KV			
	Leakage current	Max. 0.5mA			
ENVIRONMENT	Working temperature	ta: -25°C ~ 50°C tc: 90°C			
	Working humidity	20 ~ 95%RH, non-condensing			
	Storage temp., humidity	-40°C ~ 80°C, 10~95%RH			
	Vibration	10~500Hz, 2G 12min./1cycle, period for 72min. each along X, Y, Z axes.			
PROTECTION	Overtemperature	Protection type: Shut down o/p voltage, re--power on to recover			
	Over voltage protection	The no-load voltage is greater than 120%~150% rated output voltage. Shut down the output and it can be automatically restored after the fault is eliminated,			
	Short circuit protection	Protection type: 1. When the first level short-circuit protection is triggered, the fault will recover automatically after 3 seconds. 2. When the second-level short-circuit protection is triggered, the power needs to be turned on again after the fault is eliminated			
SAFETY & EMC	Withstand voltage	I/P-O/P: 3750Vac			
	Isolation resistance	I/P-O/P: 100MΩ/500VDC/25°C/70%RH			
	Safety standards	IEC/EN61347-1, IEC/EN61347-2-13			
	EMC emission	EN55015, EN61000-3-2 Class C, IEC61000-3-3			
	EMC immunity	EN61000-4-2,3,4,5,6,8,11 EN61547			
	Strobe test standard	IEEE 1789			

SUPERLIGHTINGLED

Dimensions

Unit: mm

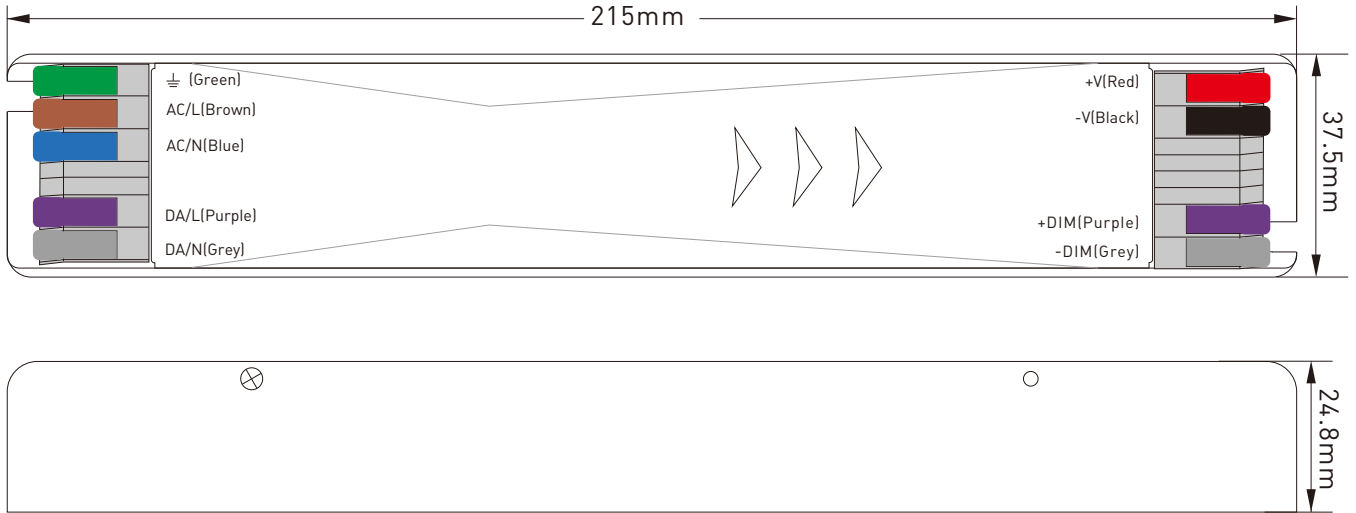

Wiring diagram

DALI Connection Mode

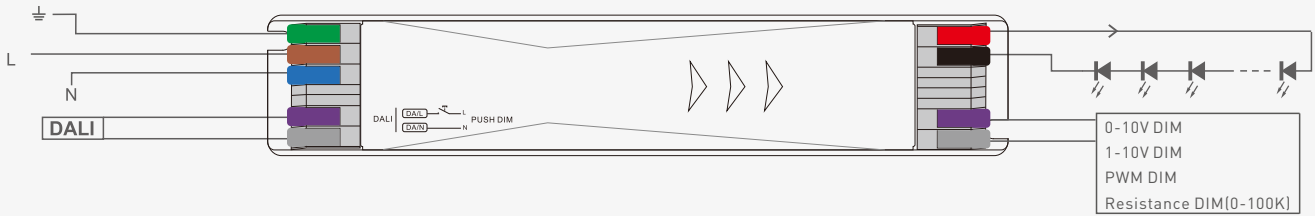

PUSH DIM Connection Mode

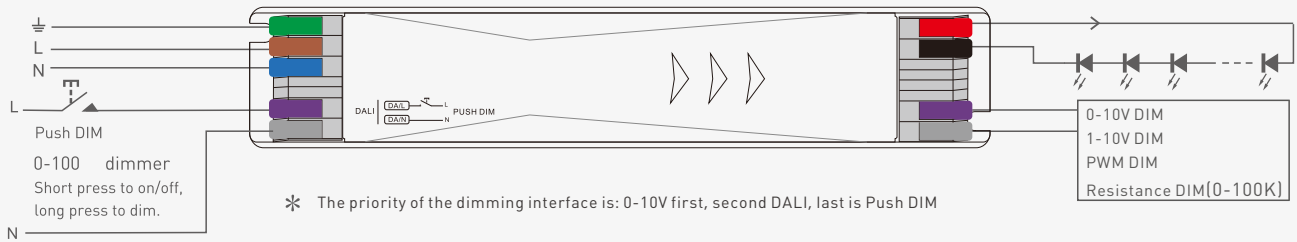

Push DIM



Reset switch

- On/off control: Short press.
- Stepless dimming: Long press.
- With every other long press, the brightness level goes to the opposite direction.
- Dimming memory: Go to the brightness level adjusted previously when lights are turned on.

Relationship diagrams

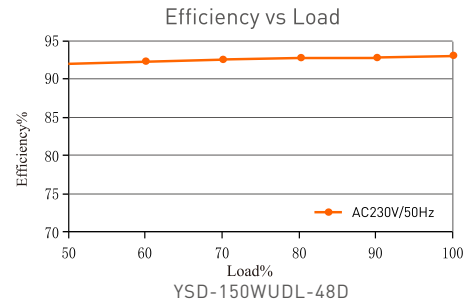
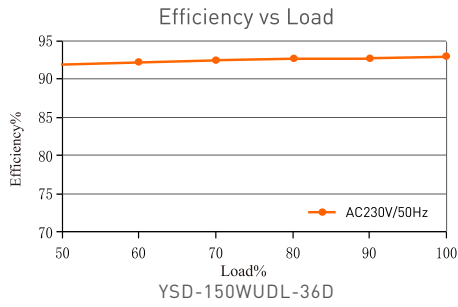
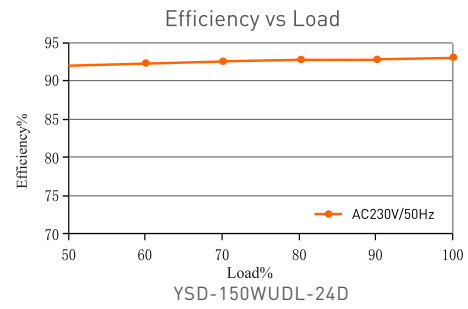
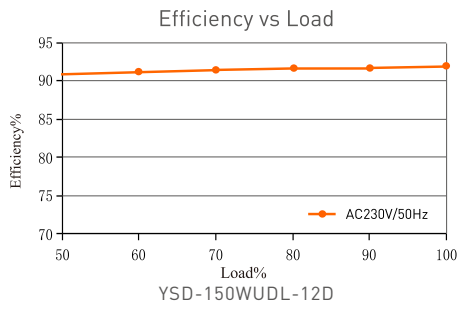

Packaging Information

DIMENSION	215x37.5x24.8mm(LxWxH)
PACKING	223x44x33mm(LxWxH)
CARTON QUANTITY	50PCS
CARTON SIZE	482x235x180mm(LxWxH)
WEIGHT	290g±10gPCS

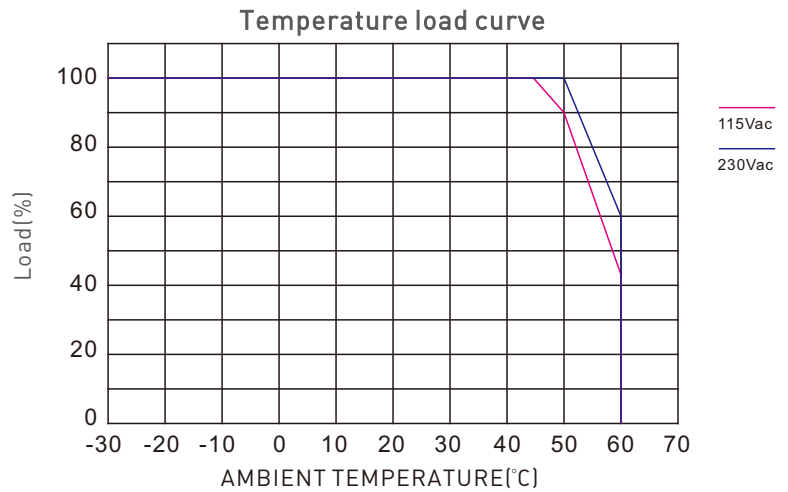

Flicker Test Form

IEEE 1789

Limit of Modulation in low risk area	
Waveform frequency of Optical output	limit (%)
$f \leq 8\text{Hz}$	0.2
$8\text{Hz} < f \leq 90\text{Hz}$	$0.025 \times f$
$90\text{Hz} < f \leq 1250\text{Hz}$	$0.08 \times f$
$f > 1250\text{Hz}$	Exemption assessment
Limit of Modulation in no effect area	
Waveform frequency of Optical output	limit (%)
$f \leq 10\text{Hz}$	0.1
$10\text{Hz} < f \leq 90\text{Hz}$	$0.01 \times f$
$90\text{Hz} < f \leq 3125\text{Hz}$	$(0.08/2.5) \times f$
$f > 3125\text{Hz}$	Exemption assessment (High frequency exemption)

Brightness

- ◆ 1%
- ▲ 5%
- ◆ 10%
- 20%
- ▲ 30%
- 40%
- ★ 50%
- 60%
- 70%
- ◆ 80%
- ★ 90%
- ◆ 100%

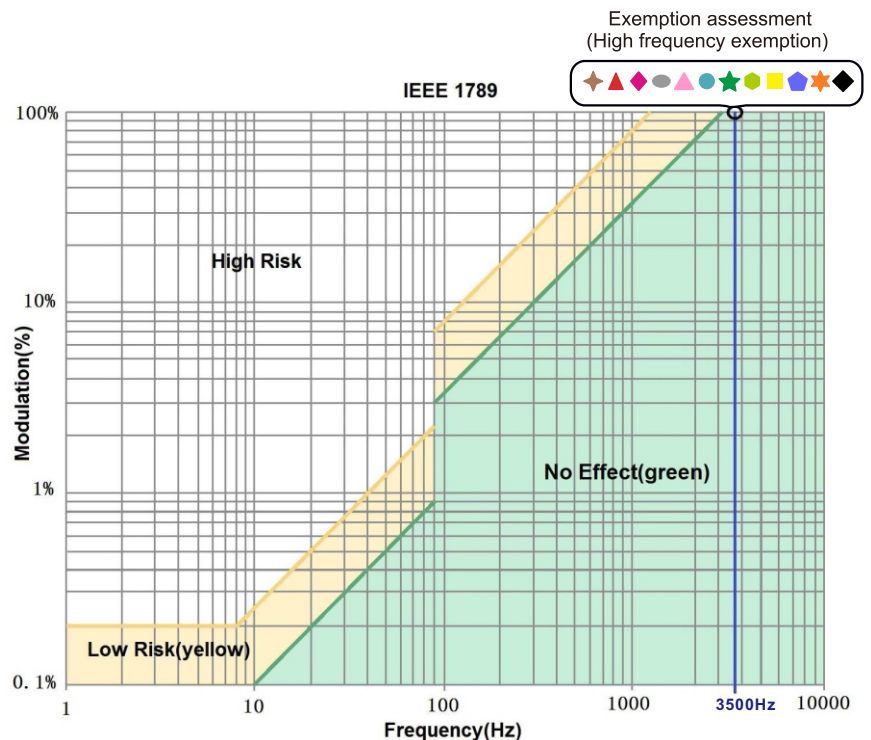

* No further notice if any changes in the manual. Product function depends on the goods. Please feel free to contact your supplier if any question.