

LTECH

DALI touch panel



EDT1



EDT2



EDT3



EDT4

Manual

www.ltech-led.com

Product Features

- Adopt DALI standard protocol IEC62386-102,207,209.
- Support switch, dimming and color adjustment function; zone control is available.
- DALI bus supply power.
- Easy to set addresses.
- Support scene, group, unicast and broadcast mode.
- Touch vibration.

Technical Specs

DALI touch panel

Power supply:	DALI power	Signal:	DALI
Control mode:	EDT1 DIM	Working temp.:	-30°C~55°C
	EDT2 CT	Dimensions(LxWxH):	86×86×37mm
	EDT3 RGB	Package size(LxWxH):	113×112×50mm
	EDT4 RGBW	Weight(G.W.):	240g



Dimensions

Unit:mm

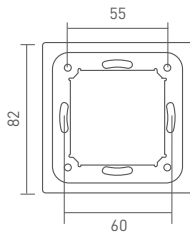
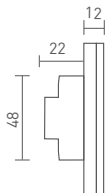
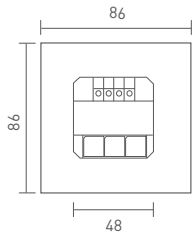

Panel Key Description

Zone keys

(unicast/group/broadcast)

Short press: turn on the lamp or select the zones, the indicator light is on.

Long press: turn off the lamp, the indicator light flashes then turns off.

Dimming circle

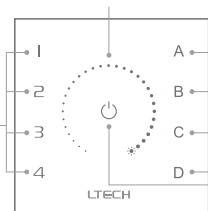

Scene keys

Short press: play scene, the indicator light is on.
Long press: save scene, the indicator light flashes.

ON/OFF

EDT1

Brightness adjustment: click ☀️, then slide the color circle after the key light is on.
CT adjustment: click 🟡🟢, then slide the color circle after the key light is on.

Zone keys

(unicast/group/broadcast)

Short press: turn on the lamp or select the zones, the indicator light is on.

Long press: turn off the lamp, the indicator light flashes then turns off.

Color circle

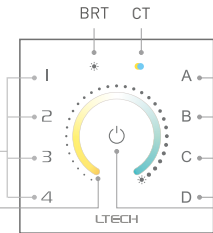

Scene keys

Short press: play scene, the indicator light is on.
Long press: save scene, the indicator light flashes.

ON/OFF

EDT2

Brightness adjustment: click ☀️, then slide the color circle after the key light is on.
RGB adjustment: click 🟢🔴🟡, then slide the color circle after the key light is on.
Saturation adjustment: click 🔄, then slide the color circle after the key light is on.

Zone keys

(unicast/group/broadcast)

Short press: turn on the lamp or select the zones, the indicator light is on.

Long press: turn off the lamp, the indicator light flashes then turns off.

Color circle

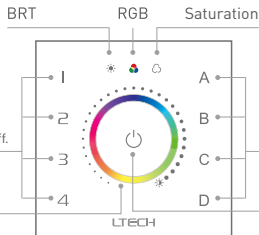

Scene keys

Short press: play scene, the indicator light is on.
Long press: save scene, the indicator light flashes.

ON/OFF

EDT3

Brightness adjustment: click ☀, then slide the color circle after the key light is on.
 RGB adjustment: click 🌈, then slide the color circle after the key light is on.
 White light adjustment: click ♻, then slide the color circle after the key light is on.

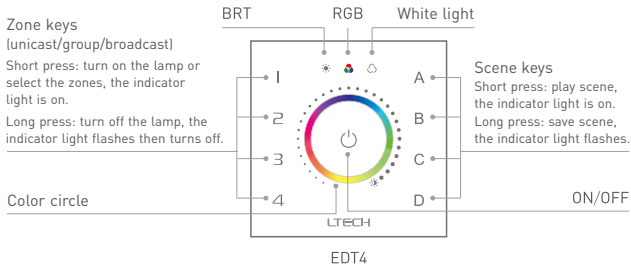

Terminals

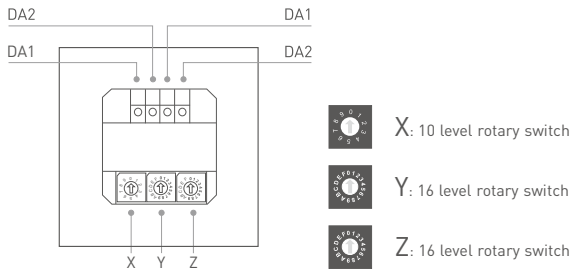

Installation Instructions

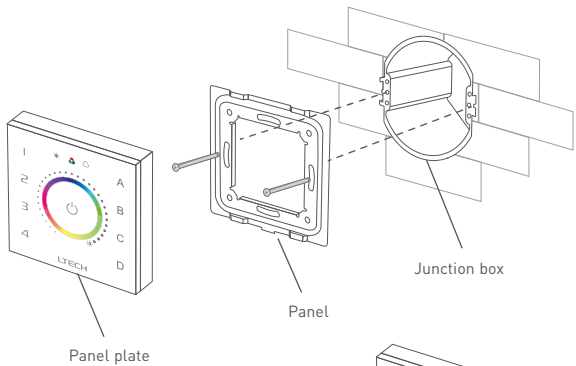

Junction boxes are as follow:



European style



86 type

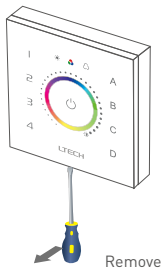

Wiring Diagram

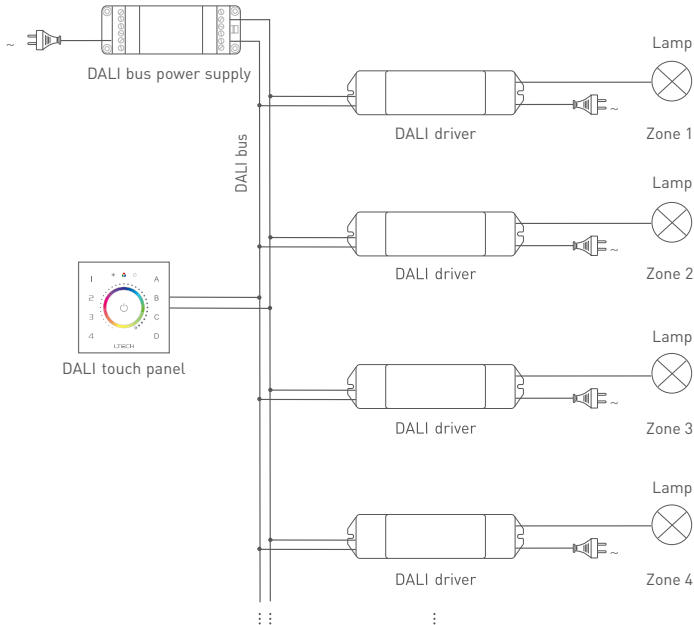

DALI Address Settings

Scene mode

Z is for scene setting, corresponding keys on the panel are A, B, C and D.



Z: scene setting
16 scenes (0-F)

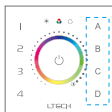

E.g. Z points to 2, the first scene value is 2.
the scene value of A, B, C, D is 2, 3, 4, 5.

E.g. Z points to E, the first scene value is 14.
the scene value of A, B, C, D is 14, 15, 0, 1.

Unicast mode



X points to 0-6



Y points to 0-9

64 unicast addresses (0-63)

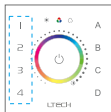

For unicast mode, please point X to 0-6.

1, 2, 3, 4 of the panel are unicast keys,
1 address value = $X \times 10 + Y$, 2,3,4 address
value are incremented by 1 in order.

E.g. how to set 1 address value = 40?
1 address value = $X \times 10 + Y = 4 \times 10 + 0 = 40$
that X points to 4, Y points to 0, now 1,2,3,4
unicast value are 40, 41, 42, 43.

Group mode

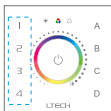

X points to 7 Y: address setting

16 group addresses (0-15)

For group mode, please point X to 7.

1, 2, 3, 4 of the panel are group keys.

E.g. Y points to 5,
then the first group value is 5,
1,2,3,4 group address value are 5, 6, 7, 8.

E.g. Y points to E,
then the first group value is 14,
1,2,3,4 group address value are 14,15, 0, 1.

Broadcast mode

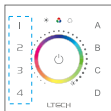

X points to 8-9

For broadcast mode, please points X to 8 or 9.

1, 2, 3, 4 of the panel are broadcast keys,
touch any one of them is workable.

Attentions

- This product must be installed and adjusted by a qualified professional.
- This product is non-waterproof (special models excepted). Please avoid the sun and rain.
- When installed outdoors, please ensure it is mounted in a water proof enclosure.
- Good heat dissipation will extend the life the product. Please install the product in a environment with good ventilation.

- When you install this product, please avoid being near a large area of metal objects or stacking them to prevent signal interference.
 - Please keep the product away from a intense magnetic field, a high pressure area or a place where lightning is easy to occur.
 - Please check whether the working voltage used complies with the parameter requirements of the product.
 - Before you power on the product, please make sure all the wiring is correct in case of incorrect connection that may cause a short circuit and damage the components, or trigger a accident.
 - If a fault occurs, please do not attempt to fix the product by yourself. If you have any question, please contact the supplier.
- * This manual is subject to changes without further notice. Product functions depend on the goods. Please feel free to contact our official distributors if you have any question.

Warranty Agreement

- Warranty periods from the date of delivery: 5 years.
- Free repair or replacement services for quality problems are provided within warranty periods.

Warranty exclusions below:

- Beyond warranty periods.
- Any artificial damage caused by high voltage, overload, or improper operations.
- Products with severe physical damage.
- Damage caused by natural disasters and force majeure.
- Warranty labels and barcodes have been damaged.
- No any contract signed by LTECH.

1. Repair or replacement provided is the only remedy for customers. LTECH is not liable for any incidental or consequential damage unless it is within the law.
2. LTECH has the right to amend or adjust the terms of this warranty, and release in written form shall prevail.