

LPD-8803/8806 Datasheet

LPD8803/LPD8806 as a new generation of driver chips are designed for the LED lighting system, which uses industrial grade CMOS process, providing multi-channel constant current driver and grayscale modulation output, it is programmable, LPD8803 and LPD8806 output 3channel and 6 channel respectively, signal particularly suitable for discrete multi-gray full-color lighting system.

Features

1. Constant current driving mode, the default driving current is 18mA, supporting LED lighting voltage up to 12V.
2. LPD8803 support three-way output (pin downward compatible with LPD6803), LPD8806 support the six outputs (pin arrangement conducive to single-panel layout).
3. Two-wire control mode, the shift clock up to 20MHz.
4. Unique data clock regeneration mechanism, super signal drive capability, support cascading length over 2000 pixels.
5. Built-in 1.2M oscillation circuit, support FREE-RUN mode, easy to programmable design (refresh rate greater than 4000Hz).
6. Built-in 256 independent PWM grayscale control circuit for each channel, 1024 grayscale effect can be achieved by programming.
7. The seven output polarity is Optional ,support an external drive or as a source of high-power LED driver circuit.
8. Industrial-grade design, input signal processing Schmidt, strong anti-interference performance.

Applications

1. LED decorative lighting system
2. PWM signal generator
3. LCD backlight driver

Pin Figure

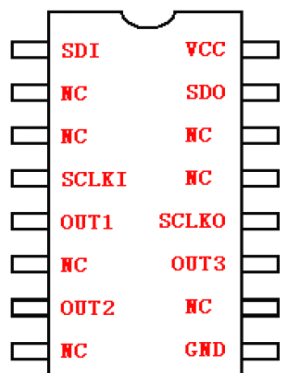

LPD8803

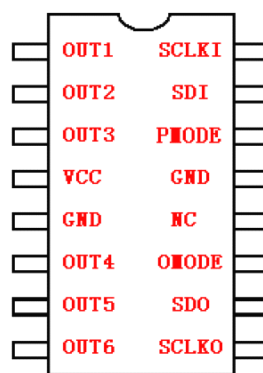

LPD8806

Pin Descriptions

SDI: Serial data input, built-in pull-up

SCLK1: Serial clock input, built-in pull-up

OUT1-OUT6: Drive output

SD0: Serial data output ,the strong internal drive output

SCLK0: Serial clock output, strong internal drive and renewable output

VCC: Power supply voltage is 3.3-5.5V, recommend an external the 10uF decoupling capacitor

OMOD: control output polarity, OMOD=1 or Null, Output of the constant current mode;
OMOD=0, Output of the plug-in drive mode

PMOD: Control single-pixel output, PMOD=1 or Null, 6-channel output independent;
PMOD=0,OUT1 and OUT2, OUT3 and OUT4, OUT5 and OUT6 are sync output,
occupies only three sets of data on the data link

NC: Empty feet

GND: Ground

Limit Parameters

† Absolute parameter

Parameter	Symbol	Range	Unit
supply voltage	V_{CC}	2.7~5.5	V
LED' voltage	V_{LED}	3~12	V
clk/dat frequency	F_{CLK}	20	MHz
max drive-current	I_{OMAX}	20 (constant current)	mA
current deviation	D_{IO}	Inner <5%, External <6%	%
power consumption	P_{DMAX}	600	mW
solder temperature	T_M	250(8S)	°C
work temperature	T_{OP}	-40~+80	°C
storage temperature	T_{ST}	-65~+120	°C

Recommended Working Parameters

Recommand parameter :

Parameter	symbol	Range	Unit
supply voltage	V_{DD}	4.5~5.5	V
input voltage	V_{IN}	-0.4~ $V_{OUT}+0.4$	V
dat/clk frequency	F_{CLK}	0~2	MHz
High-level width	T_{CLKH}	>40	ns
low-level width	T_{CLKL}	>40	ns
data setup time	T_{SETUP}	>10	ns
data hold time	T_{HOLD}	>5	ns
power consumption	P_D	<350	mW
operation temperature	T_{OP}	-20~+60	°C

Timing Parameters

Timing parameter ($T=25^{\circ}\text{C}$, $V_{CC}=5\text{V}$, $\text{OMODE}=1$)

parameter	symbol	test condition	range	unit
max rise and fall time for input signal	T_R	$V_{CC}=5\text{V}$	<500	ns
	T_F		<400	
max rise and fall time for cascade output signal	T_{TLH}	$C_L=30\text{pF}, R_L=1\text{K}$	<15	ns
	T_{THL}		<15	
max delay time for cascade output signal	T_{PD}	$C_L=30\text{pF}, R_L=1\text{K}$	<12	ns
	T_{CO}		<12	
minimum PWM opening width	T_{ONMIN}	$I_{OUT}=18\text{mA}$	400	ns
maximum opening and closing time of output signal	T_{ON}	$I_{OUT}=18\text{mA}$	<100	ns
	T_{OFF}		<80	

Inner constant current drive mode:

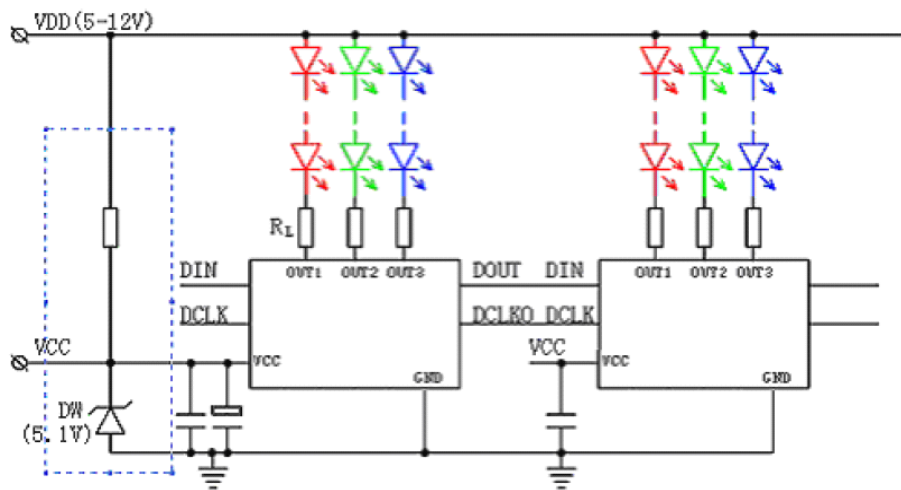

The mode ($\text{OMODE} = \text{high level or left floating}$) is applied when the V_{DD} voltage is not greater than 12V and the current of each channel is less than 18mA, if $V_{DD} < 5.5\text{V}$, the figure above within the blue dashed box can be omitted, just connect V_{DD} to V_{CC} directly .

When the figure above within the blue dashed box is omitted, the constant current $I_{LED} = 18\text{mA}$ (pls Note that after connected, in order to maintain the constant current state, the conduction-to-ground output voltage V_{OUT} must be between 0.8-5V range). The R_L here is the resistor for current limited, it can be deleted if you don't need it, when R_L is more than several 10ohms, the I_{LED} is adjustable. Also the R_L is helpful to contribute the power dissipation P_D of the chip, and to improve the working stability.

When designing the circuits, pls note that the power dissipation P_D should not bigger than the maximum P_{DMAX} , the $P_D = \sum I_{LEDX} * V_{OUTX} + P_{IC}$ (P_{IC} is the basic power consumption of the IC, normally no more than 25mW).

Note: VDD voltage can't exceed 12V for a long time, the voltage fluctuation is a little large when practical application, you can increase the capacitor of the filter on VDD, to prevent the overshoot causes damage to the output port, it is recommended to use plug-in constant voltage drive mode, as it is much safer.

the plug-in constant voltage drive mode:

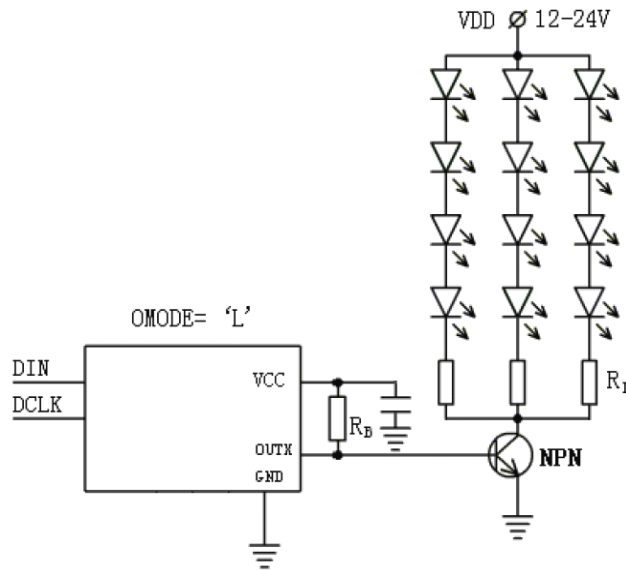

This mode (OMODE = ground) is applicable when multi-LEDs are in series, or the lamp's voltage is very high. It is actually driven by the OUT_x outputs level to control the external NPN triodes.

Current limited resistors' calculation method: $R_L = (V_{DD} - V_{LED} - V_{CE}) / 20\text{mA}$

The triodes here work in switch region, V_{CE} is the saturation voltage drop, generally adopted from 0.5V to 0.8V, the base resistance R_B can be adopted about 2K, the other signals' connected methods are the same as previous mode.

When there are many channels, and they are series connected at first, then parallel connected, this mode is also commonly used. In the series connected branch channels, any one led opens circuit, the total leds in this branch channels will be off, so pls obey the following principles: The leds' quantity in the series connected branch channels can't be too much, usually connect from 3pcs to 6pcs. In this branch channel, the parallel connected number should not be too little. It not only reduces the failure affect the face by 1pc LED's burnt off, but also breaks up the whole current limited resistors into parts. Changing the high power resistors into low power resistors, and changing concentrate installations into dispersal installations, they are useful for both heat radiation of the resistors and making the lighting designs more compacted.

Plug-in constant current drive mode:

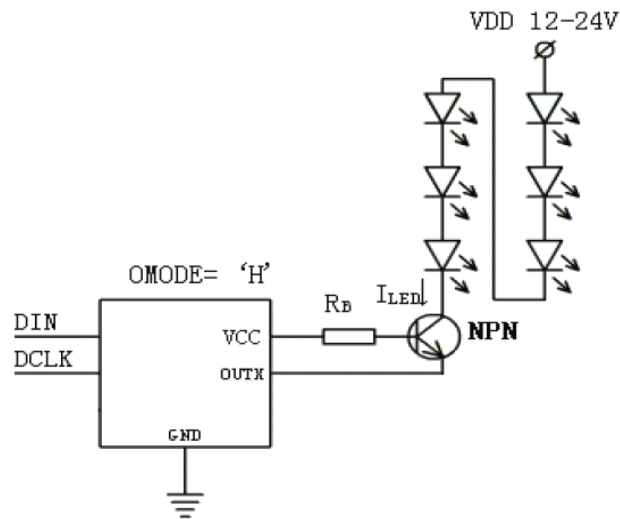

The mode (OMODE = HIGH level or floating) applicable when each single string has multiple LEDs and the VDD exceeds 12V. It is using the external NPN triodes to improve the drive voltage capability, at the same time, make all the device characteristics maintain the constant current drive: $I_{LED} = 18\text{mA}$.

The maximum VDD's withstand voltage is depended on the NPN triodes' VCEO, as usual, more than 25V.

Cascade signal's driving and connecting:

Considering the cascade transmission distance may be very long among the chips, the output ends of the SDO and SCLKO are designed with strong push-pull type drive circuits. Tests show that when the CLOCK is 2M, it can drive up to 6M signal line. To avoid the signal reflection, pls series connect a about 33ohms resistor at both ends of SDO and SCLKO, and then output to the next level during your application

Dimensions

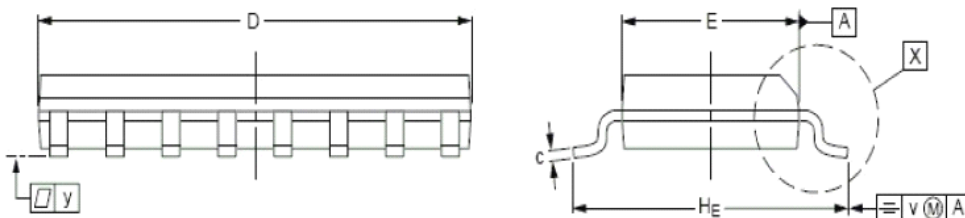

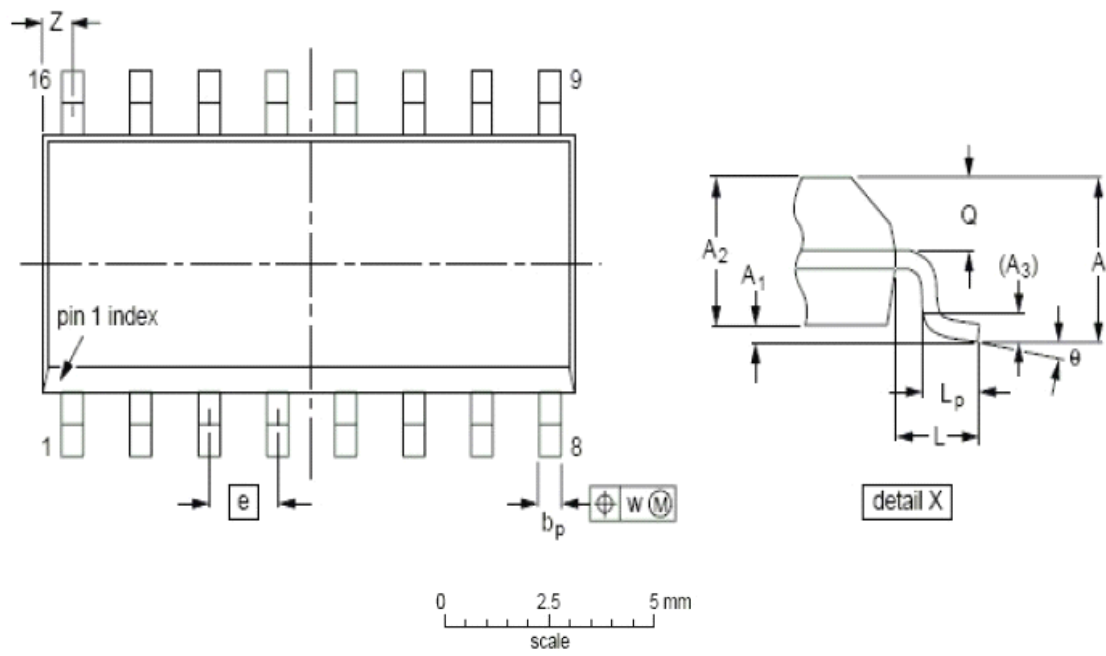

DIMENSIONS (inch dimensions are derived from the original mm dimensions)

UNIT	A max.	A ₁	A ₂	A ₃	b _p	c	D ⁽¹⁾	E ⁽¹⁾	e	H _E	L	L _p	Q	v	w	y	Z ⁽¹⁾	θ
mm	1.75	0.25 0.10	1.45 1.25	0.25	0.49 0.36	0.25 0.19	10.0 9.8	4.0 3.8	1.27	6.2 5.8	1.05	1.0 0.4	0.7 0.6	0.25	0.25	0.1	0.7 0.3	8° 0°
inches	0.069	0.010 0.004	0.057 0.049	0.01	0.019 0.014	0.0100 0.0075	0.39 0.38	0.16 0.15	0.050	0.244 0.228	0.041	0.039 0.016	0.028 0.020	0.01	0.01	0.004	0.028 0.012	

Note

1. Plastic or metal protrusions of 0.15 mm maximum per side are not included.

OUTLINE VERSION	REFERENCES				EUROPEAN PROJECTION	ISSUE DATE
	IEC	JEDEC	EIAJ			
SOT109-1	076E07S	MS-012AC				96-01-23 97-05-22